

KINEMATIC ANALYSIS OF THE 3-RPR PARALLEL MANIPULATOR

D. Chablat, Ph. Wenger

*Institut de Recherche en Communications et Cybernétique de Nantes, 1, rue de la Noë,
44321 Nantes, France*

Damien.Chablat@ircyn.ec-nantes.fr, Philippe.Wenger@ircyn.ec-nantes.fr

I. Bonev

Département de génie de la production automatisée

École de Technologie Supérieure

1100 rue Notre-Dame Ouest, Montréal (Québec) Canada H3C 1K3

Iljan.Bonev@etsmtl.ca

Abstract The aim of this paper is the kinematic study of a 3-RPR planar parallel manipulator where the three fixed revolute joints are actuated. The direct and inverse kinematic problem as well as the singular configuration is characterized. On parallel singular configurations, the motion produced by the mobile platform can be compared to the Reuleaux straight-line mechanism.

Keywords: Kinematics, Planar parallel manipulators, Singularity

1. Introduction

2. Preliminaries

A planar three-dof manipulator with three parallel RRR chains, the object of this paper, is shown in Fig. 1. This manipulator has been frequently studied, in particular in Merlet, 2000; Gosselin, 1992; Bonev, 2005. The actuated joint variables are the rotation of the three revolute joints located on the base, the Cartesian variables being the position vector \mathbf{p} of the operation point P and the orientation ϕ of the platform.

The trajectories of the points A_i define an equilateral triangle whose geometric center is the point O , while the points B_1 , B_2 and B_3 , whose geometric center is the point P , lie at the corners of an equilateral triangle. We thus have $\|\mathbf{a}_2 - \mathbf{a}_1\| = \|\mathbf{b}_2 - \mathbf{b}_1\| = 1$, in units of length that need not be specified in the paper. .

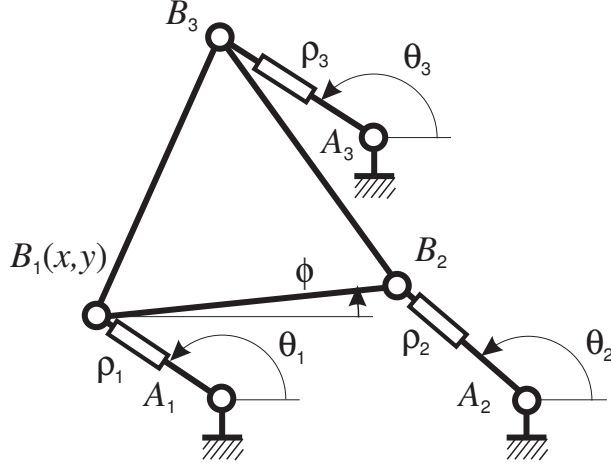

Figure 1. A three-DOF parallel manipulator

3. Kinematics

The velocity $\dot{\mathbf{p}}$ of point P can be obtained in three different forms, depending on which leg is traversed, namely,

$$\dot{\mathbf{p}} = \dot{\rho}_i \frac{(\mathbf{b}_i - \mathbf{a}_i)}{\|\mathbf{b}_i - \mathbf{a}_i\|} + \dot{\theta}_i \mathbf{E}(\mathbf{b}_i - \mathbf{a}_i) + \dot{\phi} \mathbf{E}(\mathbf{p} - \mathbf{b}_i) \quad (1)$$

with matrix \mathbf{E} defined as

$$\mathbf{E} = \begin{bmatrix} 0 & -1 \\ 1 & 0 \end{bmatrix}$$

We would like to eliminate the three idle joint rates $\dot{\rho}_1$, $\dot{\rho}_2$ and $\dot{\rho}_3$ from Eqs.(1), which we do upon dot-multiplying the former by $(\mathbf{E}\mathbf{v}_i)^T$, thus obtaining

$$(\mathbf{E}\mathbf{v}_i)^T \dot{\mathbf{P}} = \dot{\theta}_i \rho_i + \dot{\phi} (\mathbf{E}\mathbf{v}_i)^T \mathbf{E}(\mathbf{p} - \mathbf{b}_i) \quad (2)$$

with

$$\mathbf{v}_i = \frac{(\mathbf{b}_i - \mathbf{a}_i)}{\|\mathbf{b}_i - \mathbf{a}_i\|} = \begin{bmatrix} \cos(\theta_i) \\ \sin(\theta_i) \end{bmatrix} \quad \text{and} \quad \rho_i = (\mathbf{E}\mathbf{v}_i)^T \mathbf{E}(\mathbf{b}_i - \mathbf{a}_i)$$

Equations (2) can now be cast in vector form, namely,

$$\mathbf{A}\mathbf{t} = \mathbf{B}\dot{\boldsymbol{\theta}} \quad \text{with} \quad \mathbf{t} = \begin{bmatrix} \dot{\mathbf{p}} \\ \dot{\phi} \end{bmatrix} \quad \text{and} \quad \dot{\boldsymbol{\theta}} = \begin{bmatrix} \dot{\theta}_1 \\ \dot{\theta}_2 \\ \dot{\theta}_3 \end{bmatrix} \quad (3)$$

with $\dot{\boldsymbol{\theta}}$ thus being the vector of actuated joint rates.

Moreover, \mathbf{A} and \mathbf{B} are, respectively, the direct-kinematics and the inverse-kinematics matrices of the manipulator, defined as

$$\mathbf{A} = \begin{bmatrix} (\mathbf{E}\mathbf{v}_1)^T & -(\mathbf{E}\mathbf{v}_1)^T \mathbf{E}(\mathbf{p} - \mathbf{b}_1) \\ (\mathbf{E}\mathbf{v}_2)^T & -(\mathbf{E}\mathbf{v}_2)^T \mathbf{E}(\mathbf{p} - \mathbf{b}_2) \\ (\mathbf{E}\mathbf{v}_3)^T & -(\mathbf{E}\mathbf{v}_3)^T \mathbf{E}(\mathbf{p} - \mathbf{b}_3) \end{bmatrix} \quad \mathbf{B} = \begin{bmatrix} \rho_1 & 0 & 0 \\ 0 & \rho_2 & 0 \\ 0 & 0 & \rho_3 \end{bmatrix} \quad (4)$$

When \mathbf{A} and \mathbf{B} are nonsingular, we obtain the relations

$$\mathbf{t} = \mathbf{J}\dot{\boldsymbol{\theta}}, \quad \text{with } \mathbf{J} = \mathbf{A}^{-1}\mathbf{B} \quad \text{and} \quad \dot{\boldsymbol{\theta}} = \mathbf{K}\mathbf{t}$$

with \mathbf{K} denoting the inverse of \mathbf{J} .

3.1 Parallel Singularities

Parallel singularities occur when the determinant of matrix \mathbf{A} vanishes (Chablat, 1998 and Gosselin, 1990). At these configurations, it is possible to move locally the operation point P with the actuators locked, the structure thus resulting cannot resist arbitrary forces, and control is lost. To avoid any performance deterioration, it is necessary to have a Cartesian workspace free of parallel singularities.

For the planar manipulator studied, the direct-kinematic matrix can be written as function of θ_i

$$\mathbf{A} = \begin{bmatrix} -\sin \theta_1 & \cos \theta_1 & 0 \\ -\sin \theta_2 & \cos \theta_2 & \cos(\theta_2) \\ -\sin \theta_3 & \cos \theta_3 & \cos(\theta_3)/3 + \sin(\theta_3)\sqrt{3}/2 \end{bmatrix} \quad (5)$$

and its determinant is the follows,

$$\begin{aligned} \det(\mathbf{A}) &= -2 \sin(\theta_3 - \theta_1 - \theta_2) - \sin(\theta_3 - \theta_1 + \theta_2) - \sin(\theta_3 + \theta_1 - \theta_2) \\ &+ \sqrt{3} \cos(\theta_3 + \theta_1 - \theta_2) - \sqrt{3} \cos(\theta_3 - \theta_1 + \theta_2) \end{aligned} \quad (6)$$

The parallel singularities occur whenever the three axes normal to the prismatic joint intersect. In such configurations, the manipulator cannot resist a wrench applies at the intersecting point P , as depicted in Fig. 2

A special case exists when $\theta_1 = \theta_2 = \theta_3$ because the intersection point is in infinity. Thus, the mobile platform can translate along the axes of the prismatic joints, as depicted in Fig. 3.

3.2 Serial Singularities

Serial singularities occur when $\det(\mathbf{B}) = 0$. In the presence of these singularities, there is a direction along which no Cartesian velocity can be produced. Serial singularities define the boundary of the Cartesian

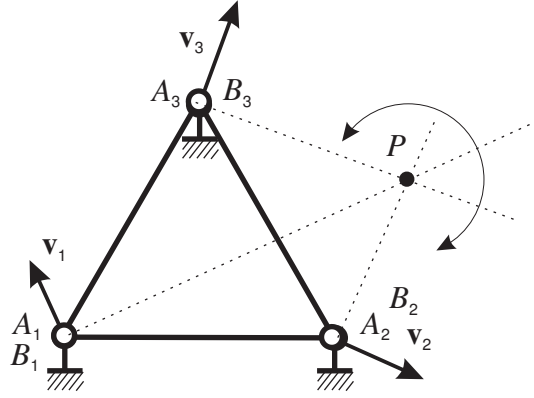

Figure 2. Parallel singularity when the three axes normal to the prismatic joint intersect

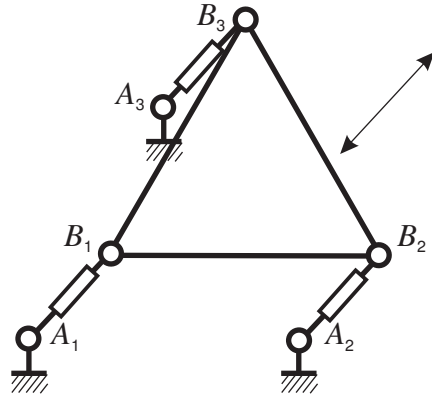

Figure 3. Parallel singularity when $\theta_1 = \theta_2 = \theta_3$

workspace. For the topology under study, the serial singularities occur whenever at least one $\rho_i = 0$ (Figure 4). When $\rho_1 = \rho_2 = \rho_3 = 0$ not any motion can be produce by the actuated joints.

3.3 Direct kinematics

The position of the base joints are defined in the base reference frame,

$$\mathbf{a}_1 = \begin{bmatrix} 0 \\ 0 \end{bmatrix} \quad \mathbf{a}_2 = \begin{bmatrix} 1 \\ 0 \end{bmatrix} \quad \mathbf{a}_3 = \begin{bmatrix} 1/2 \\ \sqrt{3}/2 \end{bmatrix} \quad (7)$$

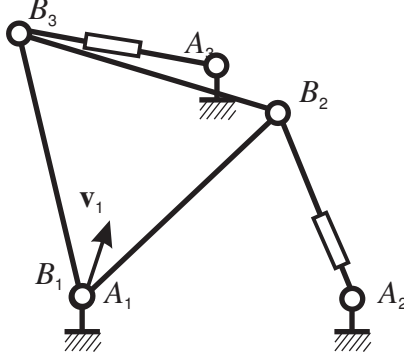

Figure 4. Serial singularity when $\rho_1 = 0$

In the same way, the position of the mobile platform joints are defined in the mobile reference frame,

$$\mathbf{b}'_1 = \begin{bmatrix} 0 \\ 0 \end{bmatrix} \quad \mathbf{b}'_2 = \begin{bmatrix} 1 \\ 0 \end{bmatrix} \quad \mathbf{r}'_3 = \begin{bmatrix} 1/2 \\ \sqrt{3}/2 \end{bmatrix} \quad (8)$$

The rotation matrix \mathbf{R} describes the orientation of the mobile frame with respect to the base frame.

$$\mathbf{R} = \begin{bmatrix} \cos(\phi) & -\sin(\phi) \\ \sin(\phi) & \cos(\phi) \end{bmatrix}$$

The position of \mathbf{p} can be obtain in three different ways:

$$\begin{cases} x = \cos(\theta_1)\rho_1 \\ y = \sin(\theta_1)\rho_1 \end{cases} \quad (9a)$$

$$\text{or} \quad \begin{cases} x = -\cos(\phi) + \cos(\theta_2)\rho_2 + 1 \\ y = -\sin(\phi) + \sin(\theta_2)\rho_2 \end{cases} \quad (9b)$$

$$\text{or} \quad \begin{cases} x = -\cos(\phi + \pi/3) + \cos(\theta_3)\rho_3 + 1/2 \\ y = -\sin(\phi + \pi/3) + \sin(\theta_3)\rho_3 + \sqrt{3}/2 \end{cases} \quad (9c)$$

To remove ρ_i from the previous equations, we multiply $\sin(\theta_i)$ (respectively $\cos(\theta_i)$) the equations in x (respectively in y) and we subtract the first one to the second one, to obtain three equations,

$$\sin(\theta_1)x - \cos(\theta_1)y = 0 \quad (10a)$$

$$\sin(\theta_2)x - \cos(\theta_2)y + \sin(\theta_2 - \phi) - \sin(\theta_2) = 0 \quad (10b)$$

$$\begin{aligned} \sin(\theta_3)x - \cos(\theta_3)y - \cos(\theta_3 - \phi + \pi/6) \\ - \sin(\theta_3)/2 + \cos(\theta_3)\sqrt{3}/2 = 0 \end{aligned} \quad (10c)$$

We obtain x and y as function of ϕ by using Eqs. 10a-b

$$x = \frac{\sin(\theta_2 - \phi + \theta_1) - \sin(\theta_1 - \theta_2 + \phi) - \sin(\theta_1 + \theta_2) + \sin(\theta_1 - \theta_2)}{2(\sin(\theta_1 - \theta_2))}$$

$$y = \frac{\cos(\theta_1 - \theta_2 + \phi) - \cos(\theta_2 - \phi + \theta_1) - \cos(\theta_1 - \theta_2) + \cos(\theta_1 + \theta_2)}{2(\sin(\theta_1 - \theta_2))}$$

Thus, we substitute x and y in Eq. 10c to obtain

$$m \cos(\phi) + n \sin(\phi) - m = 0 \quad (12a)$$

with

$$m = \sin(\theta_3) \cos(\theta_2) \sin(\theta_1) + \sqrt{3} \cos(\theta_3) \sin(\theta_2) \cos(\theta_1) - 2 \cos(\theta_3) \sin(\theta_2) \sin(\theta_1) - \sqrt{3} \cos(\theta_3) \cos(\theta_2) \sin(\theta_1) + \sin(\theta_3) \sin(\theta_2) \cos(\theta_1) \quad (12b)$$

$$n = \cos(\theta_3) \sin(\theta_2) \cos(\theta_1) + \sqrt{3} \sin(\theta_3) \sin(\theta_2) \cos(\theta_1) - 2 \sin(\theta_3) \cos(\theta_2) \cos(\theta_1) - \sqrt{3} \sin(\theta_3) \cos(\theta_2) \sin(\theta_1) + \cos(\theta_3) \cos(\theta_2) \sin(\theta_1) \quad (12c)$$

Equation 12a admits two roots

$$\phi = 0 \quad \text{and} \quad \phi = \tan^{-1} \left(\frac{2nm}{n^2 + m^2}, -\frac{-m^2 + n^2}{n^2 + m^2} \right) \quad (13)$$

A trivial solution is $\phi = 0$ which exists for any values of the actuated joint values where $x = y = 0$. This means that when configuration of the mobile platform associated to the trivial solution to the direct kinematic problem is also a serial singularity because $\rho_1 = \rho_2 = \rho_3 = 0$.

Such a behavior is equivalent to that of the *agile eye*....

3.4 Inverse kinematics

From Eqs. 10, we can easily solve the inverse kinematic problem and find two real solutions in $]-\pi \pi[$ for each leg,

$$\theta_1 = \tan^{-1} \left(\frac{y}{x} \right) + k\pi$$

$$\theta_2 = \tan^{-1} \left(\frac{y + \sin(\phi)}{x + \cos(\phi) - 1} \right) + k\pi$$

$$\theta_3 = \tan^{-1} \left(\frac{y + \sin(\phi + \pi/3) - \sqrt{3}/2}{x + \cos(\phi + \pi/3) - 1/2} \right) + k\pi$$

for $k = 0, 1$ and from Eqs. 9, we can easily find ρ_i ,

$$\begin{aligned}\rho_1 &= \sqrt{x^2 + y^2} \\ \rho_2 &= \sqrt{(x + \cos(\phi) - 1)^2 + (y + \sin(\phi))^2} \\ \rho_3 &= \sqrt{(x + \cos(\phi + \pi/3) - 1/2)^2 + (y + \sin(\phi + \pi/3) - \sqrt{3}/2)^2}\end{aligned}$$

3.5 Full cycle motion: Cardanic curve

A planar Cardanic curve is obtained by the displacement of one point of one body whose position is constrained by making two of its points lie on two coplanar lines. This curve is obtained when we set for example θ_1 and θ_2 and we observe the location of B_3 . A geometrical method to solve the direct kinematic problem is find the intersection points between this curve and the line passing through the third prismatic joint whose orientation is given by \mathbf{v}_3 . For the manipulator under study, the Cardanic curve always intersects A_3 and, apart from the singular configurations, *I*.

The loop (A_1, B_1, B_2, A_2) can be written,

$$\rho_1 \cos(\theta_1) + \cos(\phi) - 1 - \rho_2 \cos(\theta_2) = 0 \quad (16a)$$

$$\rho_1 \sin(\theta_1) + \sin(\phi) - \rho_2 \sin(\theta_2) = 0 \quad (16b)$$

We solve the former system to have ρ_1 and ρ_2 as a function of ϕ and θ_i

$$\rho_1 = \frac{-\cos(\phi) \sin(\theta_2) + \sin(\theta_2) + \cos(\theta_2) \sin(\phi)}{\cos(\theta_1) \sin(\theta_2) - \cos(\theta_2) \sin(\theta_1)} \quad (17a)$$

$$\rho_2 = \frac{-\sin(\theta_1) \cos(\phi) + \sin(\theta_1) + \sin(\phi) \cos(\theta_1)}{\cos(\theta_1) \sin(\theta_2) - \cos(\theta_2) \sin(\theta_1)} \quad (17b)$$

The position of B_3 in the base frame can be written as follows,

$$x_{B_3} = \rho_1 \cos(\theta_1) + \cos(\phi + \pi/3) \quad (18a)$$

$$y_{B_3} = \rho_1 \sin(\theta_1) - \sin(\phi + \pi/3) \quad (18b)$$

Thus, by substituting the values of ρ_1 and ρ_2 obtained in Eqs. 17a-b in Eqs. 18, we obtain the equations of the Cardanic curve,

$$\begin{aligned}x_{B_3} &= \left(\frac{-\cos(\theta_1) \cos(\theta_2)}{\cos(\theta_2) \sin(\theta_1) - \cos(\theta_1) \sin(\theta_2)} - \frac{\sqrt{3}}{2} \right) \sin(\phi) \\ &+ \left(\frac{\cos(\theta_1) \sin(\theta_2)}{\cos(\theta_2) \sin(\theta_1) - \cos(\theta_1) \sin(\theta_2)} + \frac{1}{2} \right) \cos(\phi) \\ &- \left(\frac{\cos(\theta_1) \sin(\theta_2)}{\cos(\theta_2) \sin(\theta_1) - \cos(\theta_1) \sin(\theta_2)} \right)\end{aligned} \quad (19a)$$

$$\begin{aligned}
y_{B_3} = & \left(\frac{-\cos(\theta_2) \sin(\theta_1)}{\cos(\theta_2) \sin(\theta_1) - \cos(\theta_1) \sin(\theta_2)} + \frac{1}{2} \right) \sin(\phi) \\
& + \left(\frac{\sin(\theta_1) \sin(\theta_2)}{\cos(\theta_2) \sin(\theta_1) - \cos(\theta_1) \sin(\theta_2)} + \frac{\sqrt{3}}{2} \right) \cos(\phi) \\
& - \frac{\sin(\theta_1) \sin(\theta_2)}{\cos(\theta_2) \sin(\theta_1) - \cos(\theta_1) \sin(\theta_2)} \quad (19b)
\end{aligned}$$

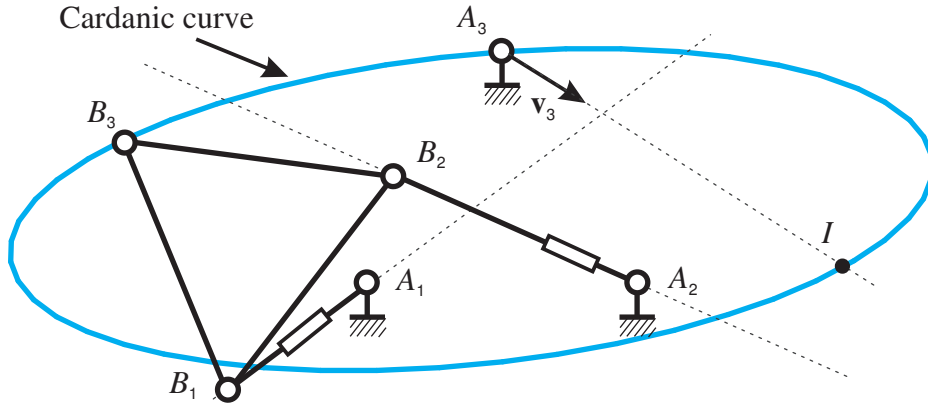

Figure 5. Cardanic curve of B_3 when B_1 and B_2 sliding along \mathbf{v}_1 and \mathbf{v}_2 , respectively

The Cardanic curve degenerates for specific actuated joint values (Hunt, 1982). In this case, the manipulator under study is equivalent to a *Reuleaux straight-line mechanism* (Nolle, 1974). This mechanism is composed by two prismatic joint and a mobile platform assembled with the prismatic joint via two revolute joints as depicted in Fig. 6. The angle between the axes passing through the prismatic joints is $\pi/3$. The mobile platform is an unit equilateral triangle. The displacement made by P is a straight line whose length is two. The magnitude of this displacement is the same for A_1 and A_2 .

Whenever $\theta_2 - \theta_1 = \pi/3$ or $\theta_1 - \theta_2 = \pi/3$ and $\theta_3 - \theta_1 = \pi/3$ or $\theta_1 - \theta_3 = \pi/3$ with $\theta_1 \neq \theta_2 \neq \theta_3$, there exists a infinity of solutions to the direct kinematic problem. This feature exists whenever we have the same condition to have a parallel singularity and the three vector \mathbf{v}_i intersect in one point. The displacement of A_i are around this point P and is magnitude is $4\sqrt{3}/3$.

4. Conclusions

A kinematic analysis of a planar 3-RPR parallel manipulator was presented in this paper. The parallel and serial singularities have been char-

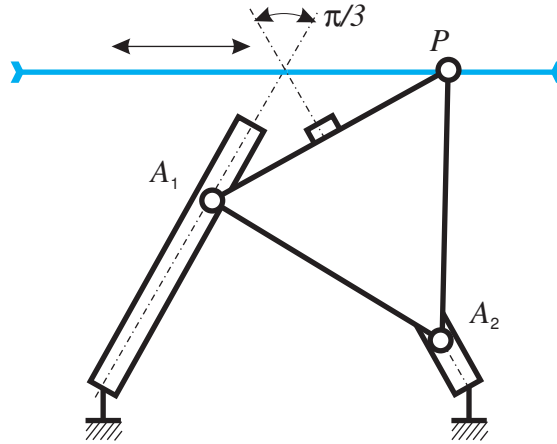

Figure 6. Reuleaux straight-line mechanism

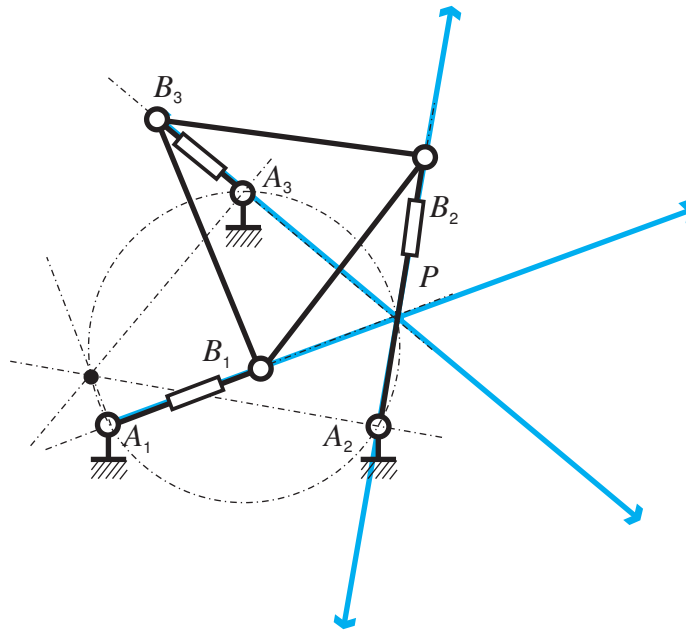

Figure 7. Degenerated Cardanic curve when $\theta_2 - \theta_1 = \pi/3$

acterized as well as the direct and inverse kinematics. This mechanism features two direct kinematic solutions whose one is a trivial singular configuration. For some actuated joint values associated to a parallel singularity, the motion made by the mobile platform is equivalent to a

Reuleaux straight-line mechanism where the amplitude of the motion is well known.

References

- Gosselin, C. and Angeles, J., *Singularity Analysis of Closed-Loop Kinematic Chains*, IEEE, Transaction on Robotics and Automation, Vol. 6, pp. 281-290, June 1990.
- Chablat, D. and Wenger, Ph., *Working Modes and Aspects in Fully-Parallel Manipulator*, Proceedings IEEE International Conference on Robotics and Automation, 1998, pp. 1964-1969.
- Merlet, J-P., "Parallel robots," Kluwer Academic Publ., Dordrecht, The Netherland, 2000.
- Gosselin, C., Sefrioui, J., Richard, M. J., *Solutions polynomiales au problème de la cinématique des manipulateurs parallèles plans à trois degré de liberté*, Mechanism and Machine Theory, Vol. 27, pp. 107-119, 1992.
- Bonev, I. and Gosselin C.M., "Singularity Loci of Spherical Parallel Mechanisms", Proceedings IEEE International Conference on Robotics and Automation, 2005.
- Tischler C.R., Hunt K.H., Samuel A.E., "A Spatial Extension of Cardanic Movement: its Geometry and some Derived Mechanisms", Mechanism and Machine Theory, No. 33, pp. 1249-1276, 1998.
- Nolle H., "Linkage coupler curve synthesis: A historical reviewII. Developments after 1875", Mechanism and Machine Theory, Vol. 9, Issues 3-4, pp. 325-348, 1974
- Hunt K.H. and Herman P.M., "Multiple Cusps, Duality and Cardanic Configurations in Planar Motion", Mechanism and Machine Theory, Vol. 17, No. 6, pp. 361-368, 1982

